



AST 7000 NT5

TELLER CASH RECYCLER

ECB FRAMEWORK COMPLIANT

AST 7000 NT5



AST 7000 NT5 is an automatic cash in-cash out recycling unit.

Designed to guarantee very high performances in counters with many cash transactions, AST 7000 NT5 ensures the security and reliability needed to project open branches, allowing at the same time to speed up cash processing operations.

The teller cash recycler handles the storage, safekeeping (the safe is available in 5 mm, **UL291**, **CEN L**, **CEN III** and **CEN IV**), and distribution **of banknotes through one input pocket**.

The unit is equipped with **8 recycling drums with a capacity up to 700 banknotes each**; the magazines are conceived with a drum technology. Banknotes' recognition is performed by CIMA's sensor BV 5000 employing all the most advanced technologies: magnetic, infrared, fluorescence, ultraviolet, visible light.

It's possible to have both the authenticity recognition function and the

fitness feature; in both cases all solutions are certified by the European Central Bank.

The very small size and innovative and pleasant look make the unit suitable for any bank environment. **AST 7000 NT5 stores and withdraws banknotes at a speed of 7 and 6 banknotes per second respectively.**

To allow an easy service the frame has been conceived in a way that it can be completely removed, so that maintenance can be done in a remote area without interrupting the teller's normal operations.

- **Considerable reduction in transactions' time both in the deposit and withdrawal phase**
- **Thanks to its high security level, it makes open branches something really possible**
- **Up to 5.600 banknotes in recycling**
- **Excellent ergonomics**
- **Its small size allows the unit's installation in any layout**
- **It doesn't require any structural modifications of the counters**
- **Real time update of balances and cash in hands**
- **It improves productivity and customer service**
- **Prevention of human errors thanks to high level authenticity detectors**
- **Multicurrency operation**
- **Possibility to return the last deposit made**
- **It considerably reduces the cash in hand within the branch**

- **Provided with software and hardware for the management of alarms and security locks**
- **Extremely compact maintenance footprint: possibility of remote servicing**
- **Fitness feature available in compliance with the ECB framework**
- **When equipped with the fitness feature the banknotes distributed by the unit can be directly fed into ATM devices without using the CIT money**
- **Possibility of remote management through the C-Link platform**

TECHNICAL SPECIFICATIONS

SAFE

5 mm, 12 mm (UL 291 and CEN L),
40 mm (CEN III and CEN IV)

WEIGHTS

From 165 kg to 480 kg according to the configuration

ELECTRICAL CHARACTERISTICS

Voltage 90 – 240 V AC
Frequency 50 – 60 Hz
Power input 600 W

CONNECTIONS

Serial port RS232
or USB 1.0 port or ethernet

NUMBER OF DRUMS HANDLED

8

DEPOSIT CAPACITY

Up to 700 banknotes each drum

DRUMS' MANAGEMENT

- Storage by single denomination with recycling function
- Multi-denomination storage with stocking and recycling function
- Drums' flexibility

BANKNOTES' DETECTOR

Authenticity ECB certified
Possibility of multi-currency operation
Fitness ECB certified

DEPOSIT AND WITHDRAWAL SPEED

Up to 7 banknotes/second

SIZE OF THE BANKNOTES HANDLED (standard configuration)

Length
from 100 mm to 190 mm
Width
from 60 mm to 82 mm

SECURITY

- Handling of 20 time bands
- 3 different alarm outputs
- Timed handling of locks



info@cimspa.it

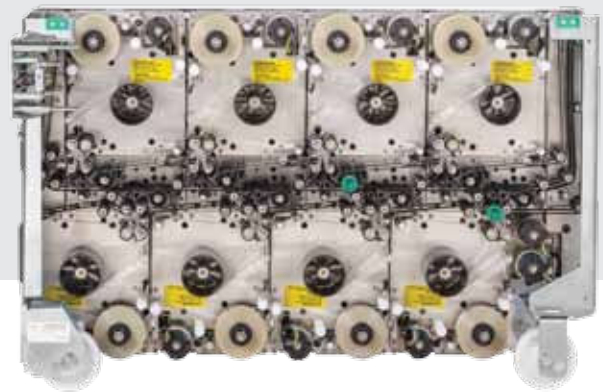
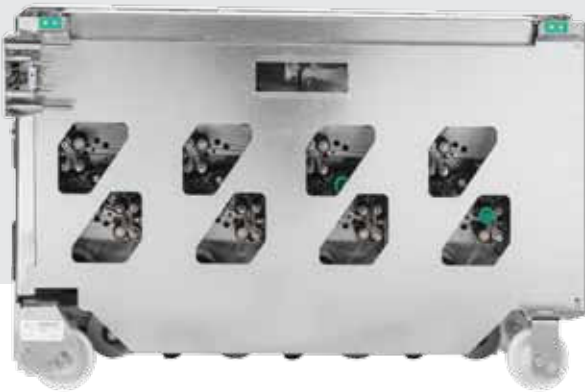

DIMENSIONS

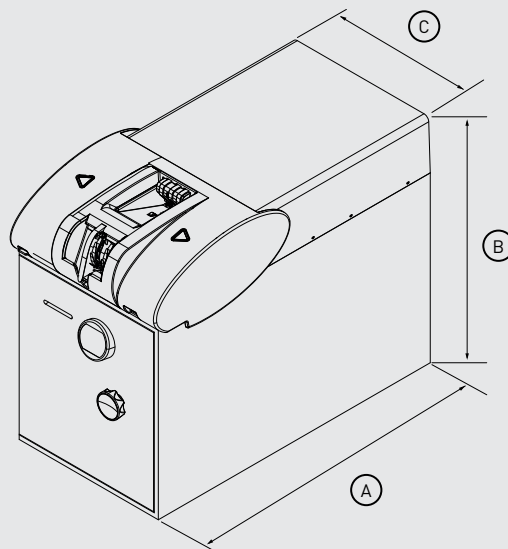
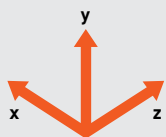

	860mm - UL291
(A)	880mm - 5mm
	920mm - CEN L
	1000mm - CEN III and CEN IV
	670mm - UL291
(B)	670mm - 5mm
	670mm - CEN L
	737mm - CEN III and CEN IV
	440mm - UL291
(C)	440mm - 5mm
	495mm - CEN L
	495mm - CEN III and CEN IV

Specifications can be subject to change without notice.



CIMA S.p.A. - P.IVA IT03536420361
Via Di Mezzo 2/4 - 41037 Mirandola (Modena) - Italy
Tel. +39 0535 418611 - Fax +39 0535 23062
www.cimaspa.it // info@cimaspa.it